

1 2 3 4 5 6 7 8

REVISIONS		
ISS	ZONE	DESCRIPTION\APPROVED\DATE

業務部

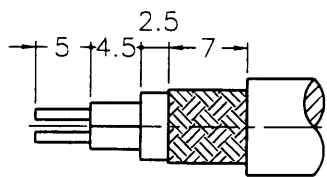

RECOMMENDED CABLE STRIPPING DIM'S

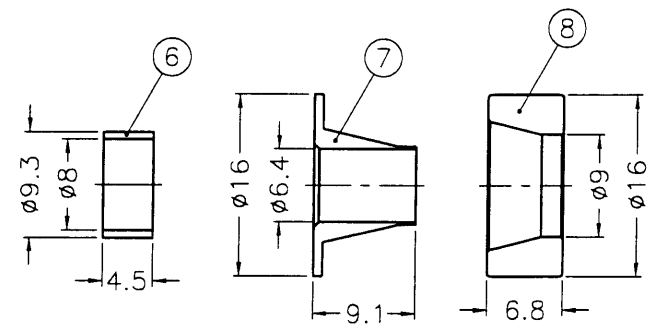
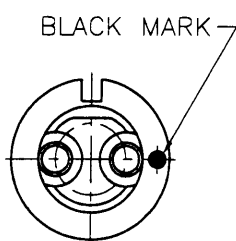
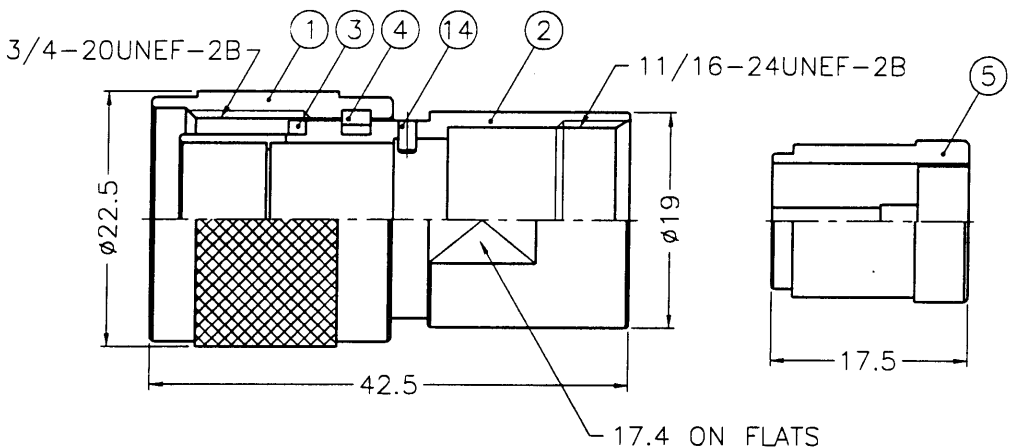

NOTES: FINISH (PLATING THICKNESS IN MICRO-INCHES)  
 1. BRASS PER QQ-B-626  
 2. BRASS PER QQ-B-613  
 3. NICKEL PL. 100 MIN. THICK OVER COPPER STRIKE  
 4. GOLD PL. 3 MIN. THICK OVER NICKEL PL. 100 MIN. THICK OVER COPPER STRIKE  
 5. SILVER PL. 200 MIN. THICK OVER COPPER STRIKE

出圖  
87.10.08  
R&D

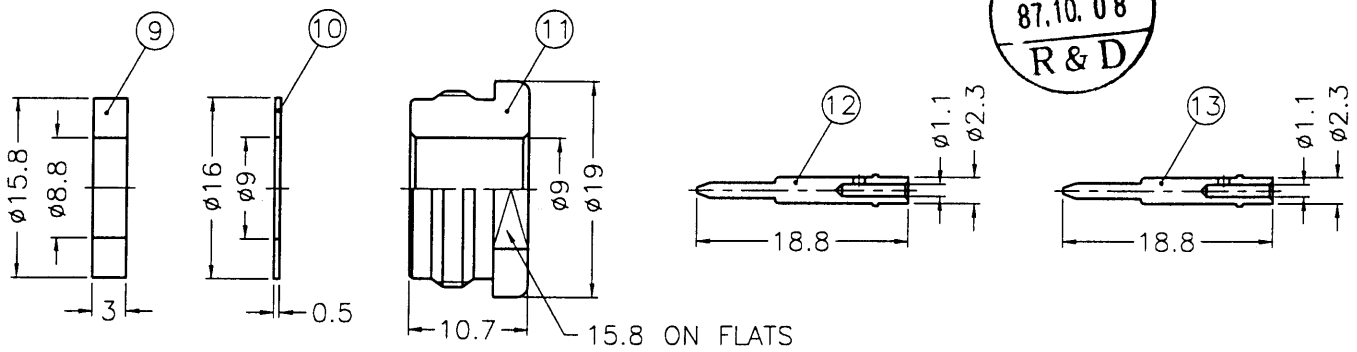

14	PIN	NOTE 1	NOTE 3	1	TW5620-12
13	CONTACT PIN	NOTE 1	NOTE 5	1	TW5622-12-23/11
12	CONTACT PIN	NOTE 1	NOTE 4	1	TW5622-12-23/11
11	NUT	NOTE 1	NOTE 3	1	TW5622-11-19/9
10	WASHER	NOTE 2	NOTE 3	1	WS-16/9X05
9	GASKET	SILICONE	RED	1	GS-158/88X3
8	COMPRESSOR	NOTE 1	NOTE 3	1	TW5622-8
7	BRAID CLAMP	NOTE 1	NOTE 3	1	TW5622-7
6	RING	DELTRIN	NATURAL	1	TW5621-6
5	INSULATOR	PBT	WHITE	1	TW5622-5
4	RETAINER RING	SUS 304	NATURAL	1	N5000-7-C
3	GASKET	SILICONE	RED	1	GS-17/145X15
2	BODY	NOTE 1	NOTE 3	1	TW5622-2
1	SHELL	NOTE 1	NOTE 3	1	TW5620-1
NO.	DESCRIPTION	MATERIAL	FINISH	Q'TY	DRAWING NO.

DIMENSIONS ARE IN MILLIMETERS				PART NO.	
UNLESS OTHERWISE SPECIFIED TOLERANCES					
0.5-6	=	±0.2			
6-30	=	±0.4			
30-120	=	±0.6			
120-315	=	±1			
315-1000	=	±1.6			
1000-2000	=	±2.4			
SCALE	1.5/1	ISSUE	A	APPROVED	DATE
				10-01-98'	
				CHECKED	DATE
				10-01-98'	
				DRAWN	DATE
				10-01-98'	

KAI JACK INDUSTRIAL CO., LTD. TAINAN TAIWAN R.O.C.	
TITLE	
TWINAXIAL CLAMP PLUG	
DRAWING NO.	
KJ-TWX1141K1-NPBS/G-95	
FILE NO. F:\DWG\TWX\1141K1\95\NPBSG	

F  
E  
D  
C  
B  
A

F  
E  
D  
C  
B  
A

1 2 3 4 5 6 7 8 TWX-R032